

MIRACO 3370-S
INSTALLATIONS AND SPECIFICATIONS

READ CAREFULLY



A DIVISION OF
AHRENS AGRICULTURAL INDUSTRIES, INC.
BOX 686
GRINNELL, IOWA 50112
PHONE 641-236-5822
TOLLFREE 1-800-541-7866
FAX 1-641-236-3341
Website: www.miraco.com

2011 SPECIFICATIONS

PART 1 - GENERAL

A. DESCRIPTION:

1. The MiraFount is the finest operating, lowest cost, energy-free livestock waterer on the market today. The sealed atmosphere helps prevent the formation of scum and algae. It also prevents tongue injuries from contact with frigid steel.
2. The earth temperature of the water will keep your MiraFount flowing in cold weather and also keeps the water cool in hot weather. Thermal engineering and special design of the lid closures make it work in all types of weather.
3. All edges are curved and sloped to prevent injury to people and animals. No energy is required, eliminating the danger of electrocution and fire hazards.

B. WEIGHTS & DIMENSIONS:

Model	Capacity	Gallons/ L	Description	Dimensions	Wt.
3370-s	350 hd beef	100 Gal	6 openings:	45 1/2" x 57 1/2" x 19"	216lb
	120 hd dairy	378.54L	9 1/2" (24.13cm)	(115.57cm x 146.05cm x 48.26cm)	97.98kg

C. MATERIAL NECESSARY FOR INSTALLATION:

1. Concrete
2. P.V.C. Glue
3. 1-#834 Heat Tube recommended.
4. Thread sealer or teflon tape

NOTE: Southern USA regions do not require as large a heat well.

PART II - MATERIALS, PRODUCTS

A. MATERIALS:

1. High impact Rockite™ polyethylene.

B. INSULATION:

1. The base, cover and lid closures are filled with a 3" (7.62cm) thickness of Urethane foam.

C. VALVE:

1. Miraco plastic valve with brass rods and thumb screws.

MIRAFOUNT #3370-S INSTALLATION INSTRUCTIONS



Step 1

Install your heat well at least 1' (2.54cm) below frost or down to your water line to insure frost free operation. Install the water line so it comes up close to the center of the heat well. always allow the cement to harden at least 72 hours before you continue to next steps.



Step 2

Pull the paper backing off the rubber gasket furnished in your parts carton. Stick this gasket on the bottom of your tank. Keep the gasket as close to the edge as possible. This is necessary to keep air out and keep your heat well dry.



Step 3

Place the tank over the fill line and position it so the fill line is centered in the pit. Using a 3/8" (.95cm) cement drill, drill the anchor holes. Note on some tanks it is necessary to be off center a little to make sure the tank covers the hole



Step 4

Pound the anchor bolts in and tighten evenly.



Step 5

The 4" (10.16cm) pipe is not glued in so it can be removed from the fitting in the bottom of the tank. This leaves your 3/4" (1.90cm) line standing up into the tank.



Step 6

Measure up 11 3/4" (29.84cm) from the ledge on the inside of the 4" (10.16cm) male fitting and make a mark on the pipe with a pen or pencil

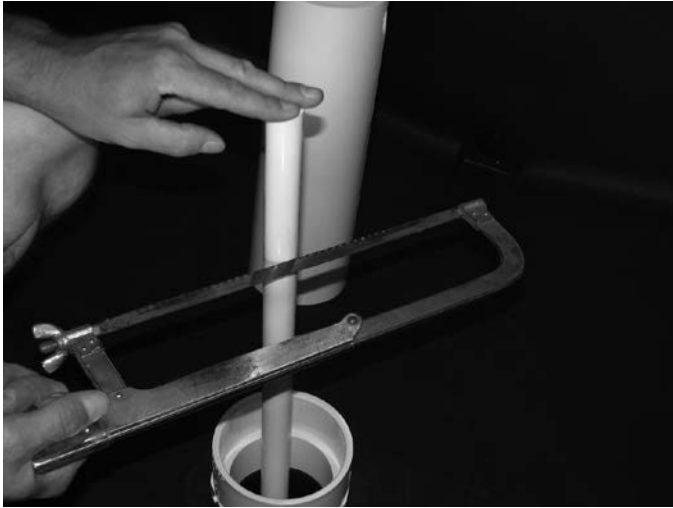

Step 7
Using a hacksaw, cut off the $\frac{3}{4}$ " (1.90cm) fill line at the mark you made earlier.



Step 8
Slide the pipe insulation on the $\frac{3}{4}$ " (.95cm) fill line. Leave it about 1 $\frac{1}{2}$ " (3.81cm) down from the top of the pipe.



Step 9
Apply pipe dope to the threads of your fittings and screw it into place securely.



Step 10
After the fitting is tightened into the "T" fitting, apply PVC cement to the $\frac{3}{4}$ " (1.90cm) pipe and install the "T" assembly.



Step 11
Make sure the fitting is straight across and runs parallel with the sides of the tank. It must be straight or the floats will hit on the underside of the lid.



Step 12
Apply PVC cement to the bottom of your 4" (10.16cm) pipe.



Step 13
Push the 4" (10.16cm) pipe into the lower fitting and align quickly with the "T" fitting so the holes line up with the "T" fittings threaded ends.



Step 14
Apply pipe dope to the 3/4" (1.90cm) pvc adapters.



Step 15
Tighten the 3/4" (1.90cm) PVC fittings into the "T" as shown.



Step 16
Tighten both 3/4" (1.90cm) fittings.



Step 17
Apply pipe dope or teflon tape to the threads on the valve.



Step 18
Screw the valves into the 3/4" (1.90cm) adapter installed earlier



Step 19

Tighten both valves. Hand tight in most cases is sufficient. Make sure the valves are straight. Put your drain plugs in from the inside.



Step 20

Install the arms and floats. When setting your water level, adjust the valves so one will shut off before the other. This seems to make them shut off better. Make sure thumb screws are very tight so the water level stays constant. Put the balls in the bottom of the tank and fill. Fill until the balls seal loosely in the holes.

Step 21

When ready to start cattle, push the balls back and lock back with the fiberglass rods provided.

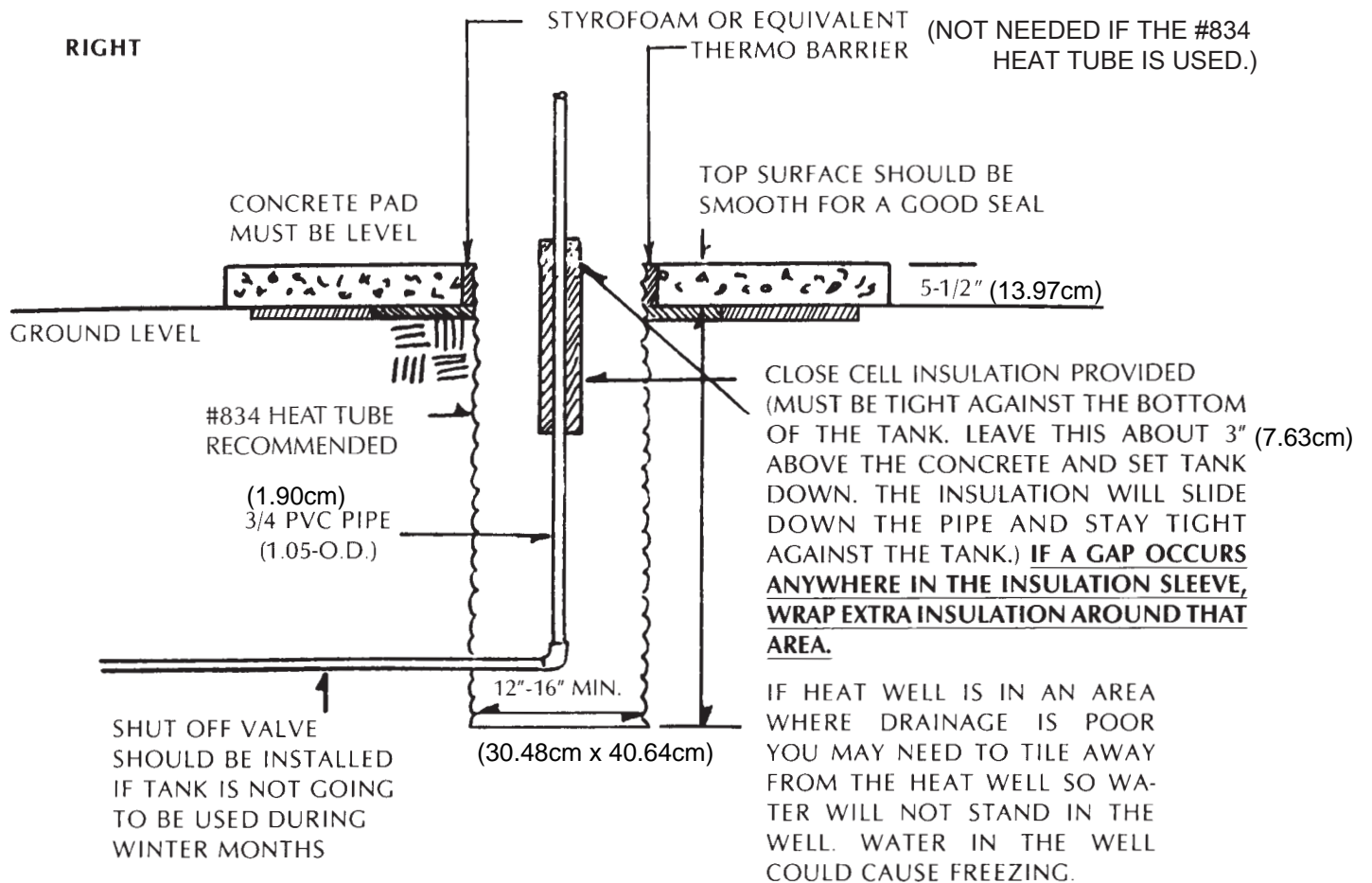

WRONG

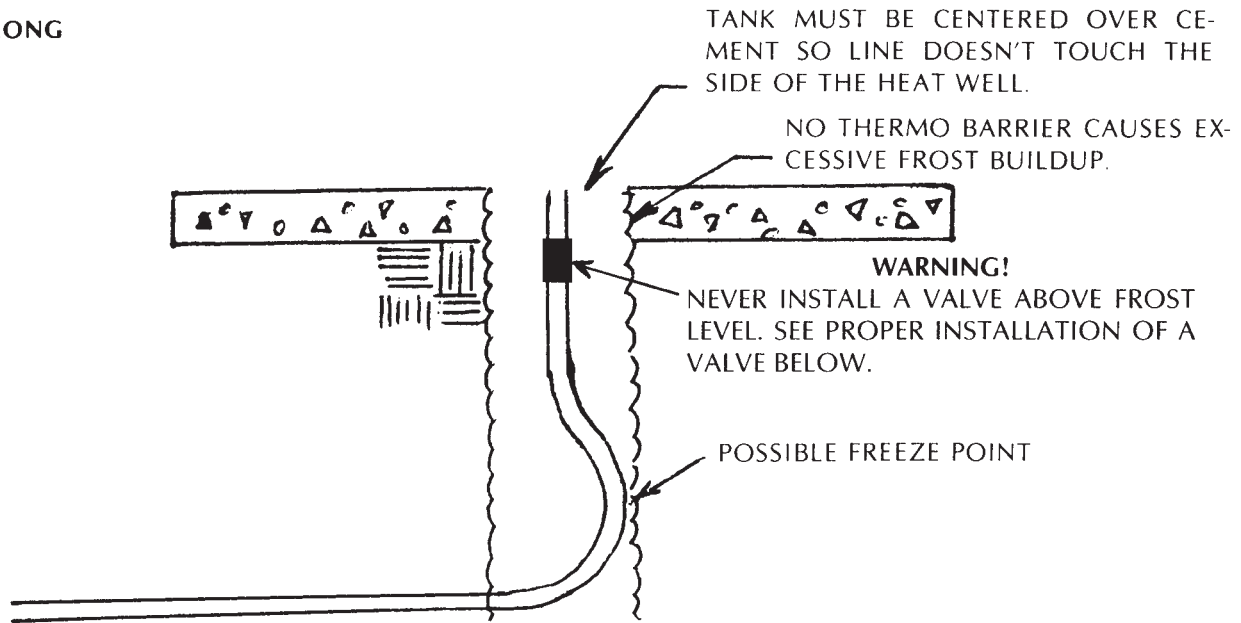

PROPER INSTALLATION OF DRAIN BACK SHUTOFF VALVE

RUN THIS ROD THROUGH THE VENT PIPE IN THE WATERER. WELD A LARGE HEX NUT ON TOP, SO A WRENCH CAN BE USED TO SHUT OFF THE WATER BELOW.

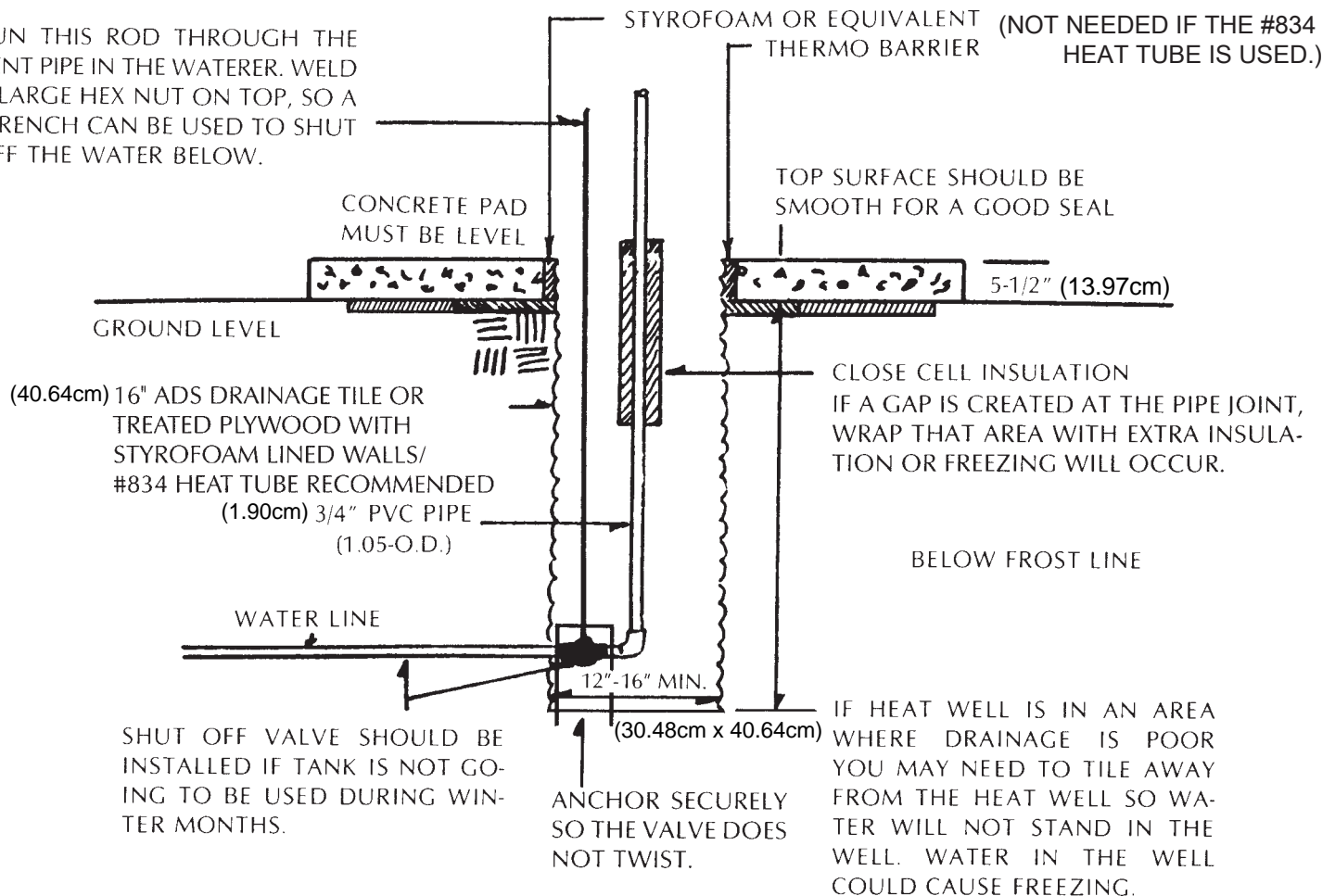

MODEL 3370-S

MANAGEMENT TIPS

1. A fiberglass rod is to be used to hold the balls back for training livestock. The fiberglass rod is inserted into a threaded insert in the baffled portion of the lid. This holds the balls back for training.
2. For short periods of time when you're not using the MiraFount in winter, you can dip 3-5 gallons (11.36L- 18.93l) of water out every day and the tank will sustain itself until livestock are using it again. If you plan on not using it for a long time, merely drain it and shut off the water. This is where the shut off valve comes in handy.
3. Water level is very important. If the water is too high the balls will stick shut in the winter time and the tank will appear frozen. A kick or a small amount of hot water on the balls will fix the problem. Then lower the water level so this won't happen again. However, never lower water below the baffle or cold air could go under and freeze your valve.
4. In case of power failure, merely keep the livestock away from the waterer so they can't drink it down. If this has already happened, then a small amount of hot water is all you need. NEVER USE AN OPEN FLAME TO THAW ICE
5. Management is necessary in any operation and this includes checking your waterer daily. Water is very important and any malfunction should be attended to immediately. This is good practice for any make of waterers.
6. MiraFounts must be installed level, otherwise one ball will be higher than the others.
7. The MiraFount should be cleaned periodically, especially the ones being used for hogs. Mud can hamper the proper operation of the MiraFount since the balls have to move freely in order to have proper operation.
8. If your valve is seeping, check the valve for foreign materials first. This is the biggest cause of seeping valves. If you have extremely rusty water or dirty water, your valve should be cleaned periodically.
9. If you have any questions give us a call at 641-236-5822
10. If valve persists on leaking, use an allen wrench to tighten the orifice under the plunger. Turn clockwise to tighten.
11. Drain plugs are to be placed inside the tank to plug the drain hole.